

INSTRUCTION SHEET

CSS | Continuous Run

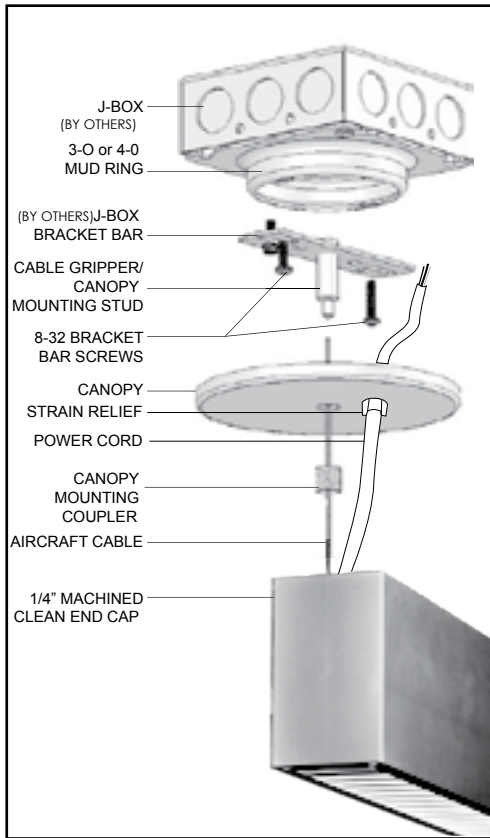

STND - 5" CANOPY
NON POWER FEED

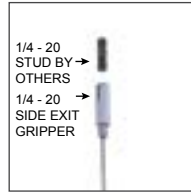

NC-NO CANOPY
NON POWER FEED

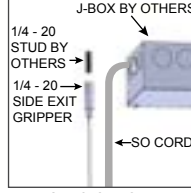

NC-NO CANOPY
POWER FEED



CR - SEAMLESS
CONTINUOUS RUN

CSS Cable Suspension

1. See appropriate Stand Alone or Continuous Run Matrix for correct J-box (by others) spacing.
2. Secure bracket bar to mud ring or in the case of "NC" option mount 1/4-20 stud to structure and install cable gripper.
3. Cut cables to desired length – be careful not to fray cable ends
4. Insert cable into gripper ends and adjust to desired length
5. Insert AWM cord through canopy and secure with provided strain relief
NC option, AWM needs to run into a jbox (by others) using provided 1/2" strain relief.
6. Complete wire make-up
7. Install canopy with canopy mounting coupler

Continuous Run Info:

1. Install starter fixture (aircraft cable & power feed) following 1-6 above.
2. Remove lens and liner of adjacent fixture
3. Install next fixtures aircraft cable and slide open end of fixture (side without a cable setup) into starter fixture's continuous run pinch brackets and alignment splines or guide pins.
4. Secure with supplied washers and nuts on pinch bracket (Note: the internal "L" bracket should be set back 1/16" from the edge of the fixture – they can be adjusted if necessary)
5. Tighten set screws on the alignment splines if used.
6. Ensure fixtures are level and securely tightened to each other to avoid potential light leak between housing.
7. Thru wire with appropriate gauge wire if integral ballast/driver. All pre-installed thru wire QCS quick connects (if applicable) are rated for max. 9 amps. Do not exceed this rating.
8. Continue installation for all other fixtures in the row, by repeating 2-7.
9. Replace all liners, install lamps (if fluorescent), install all lenses or louvers. Ensure all connections are secure.

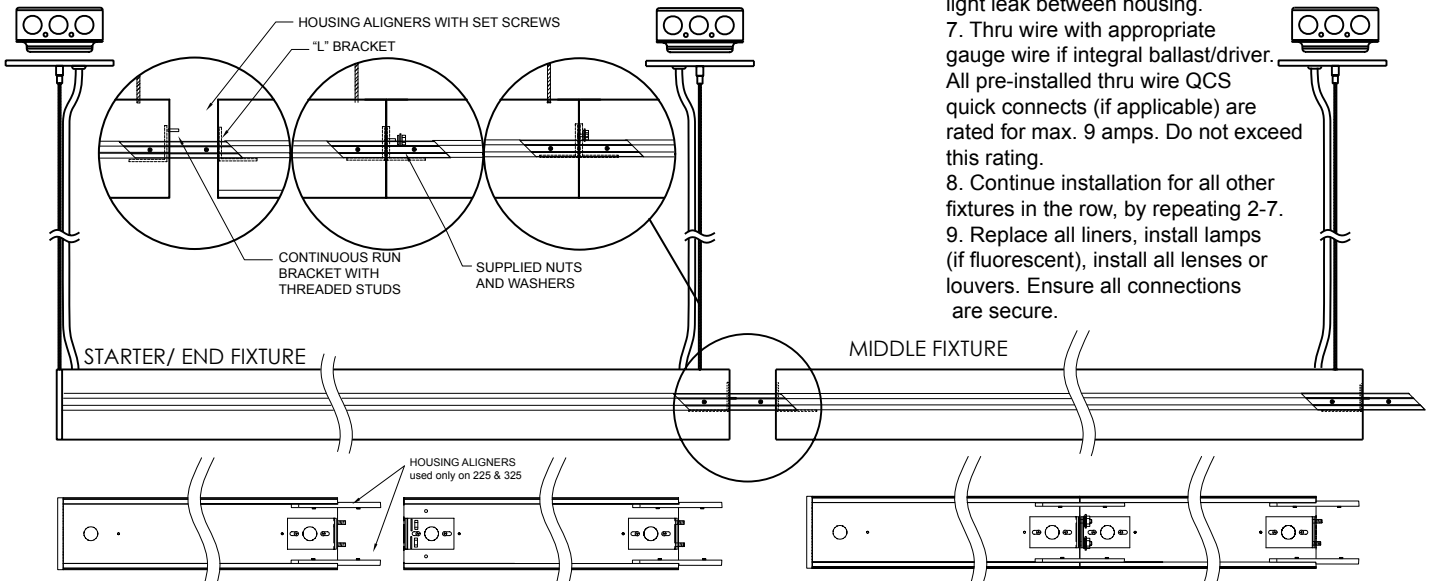

Note: To be installed by a qualified electrician per N.E.C. and all local codes.

820-00068
V-0117